



i8-M40
Medical Incinerator

The i8-M40 is one of the smallest medical incinerators in our range. The top loading design means liquids are well contained within this system during incineration. The i8-M40 is perfect for small clinics, dental practices or small medical facilities where waste streams are quite low.



Industry Leading Insulation

Coretex© insulation is a specially formulated substrate containing various levels of material that ensure almost all of the heat generated within our incinerators stays inside them - increasing performance and efficiency to another level.



Long Lasting Construction

The i8-M40 internal frame is constructed from British made high quality 3mm mild steel plate.

They are fully welded for maximum strength by our time-served coded welders and now fully clad in 'cool touch' stainless steel. Meaning you get years of trouble-free operation.

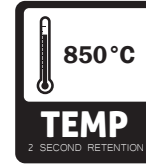

Designed to excel

Each of our incinerators has been tested to exacting standards ensuring they meet our strict guidelines.

This machine can reach in excess of 850°C in the secondary chamber and also retains the gases for the 2 seconds required.



Designed to burn Type I - IV pathological waste and infectious and contaminated "red bag," surgical dressings, plastic test devices and other wastes.

If you are paying a high fee to haul these waste materials to a disposal site, now is the time to consider the on-site Incineration alternative. On-site incineration is a thorough, fast, and cost effective way to dispose of waste. Our various models are engineered to meet strict air emission regulations without offensive smoke or odour.



- Cladded for heat retention, cool touch & hygiene control
- Rapid, complete and efficient medical waste disposal
- Patented safety handle for easy access to chamber
- High quality refractory lining and insulation
- Easy to use CE2 control panel
- Programmable temperature control for complete combustion
- Secondary chamber* with 2 second retention time
- Fast pre-heat and continual high temperature performance
- Low energy consumption levels



* Our primary combustion chambers are constructed from high grade steel and monolithic refractory lining with a unique concave design to prevent cold spots. The design ensures a natural secondary burn characteristic as when the burner is switched on a flame curtain is created, this ensures the thermal breakdown of smoke/emissions, where in many instances emissions will exit through the stack and into the atmosphere in the form of clean vapor.



For additional information, or to speak to one of our expert team:

Call +44 (0) 1704 884020

Email sales@inciner8.com



Key Parts of our Incinerator

model: i8-M40

- 1 Dual HT Thermocouple**
Allow independent control of primary and secondary temperatures via the control panel.
- 2 Primary Chamber**
Chamber designed for maximum air flow and circulation which in turn improves efficiency and total burn time.
- 3 Low NOx Burners**
These are some of the cleanest, most efficient burners available today. These can be supplied as gas or oil fired.
- 4 Chimney Stack**
Stainless steel stack for longevity. Minimum 3m stack height required. Fitted with dispersion cap as standard.
- 5 Secondary Chamber**
Retains and re-burns the exhaust gases for minimum of 2 seconds at 850°C to meet EU guidelines.
- 6 'Cool Touch' Cladding**
Steel cladding to reduce risk of infection and increase longevity of system.
- 7 Safe Use Handles**
Easy to open and close loading door. Designed to increase operator safety.



How incineration works:

Incineration is a waste treatment process that involves the combustion of organic substances contained in waste materials. Incineration and other high-temperature waste treatment systems are described as “thermal treatment”. Incineration of waste materials converts the waste into ash, flue gas and heat.

The ash is mostly formed by the inorganic constituents of the waste and may take the form of solid lumps or powder. In some cases, the heat generated by incineration can be used to generate electric power.

Applications

Our versatile range of medical incinerators are designed for a wide range of waste types. This particular model benefits from a front loading design and very simple operation process. Ideal as a stand-alone machine where limited staff are available to operate.

- Type I - IV pathological waste
- Infectious and contaminated “red bag”
- Surgical dressings
- Plastic test devices
- Vials & syringes
- Yellow bags
- Bandages and gauzes
- Other forms of pharmaceutical waste.



For additional information, or to speak to one of our expert team:

Call
+44 (0) 1704 884020

Email
sales@inciner8.com

 **INCINER8**
www.inciner8.com

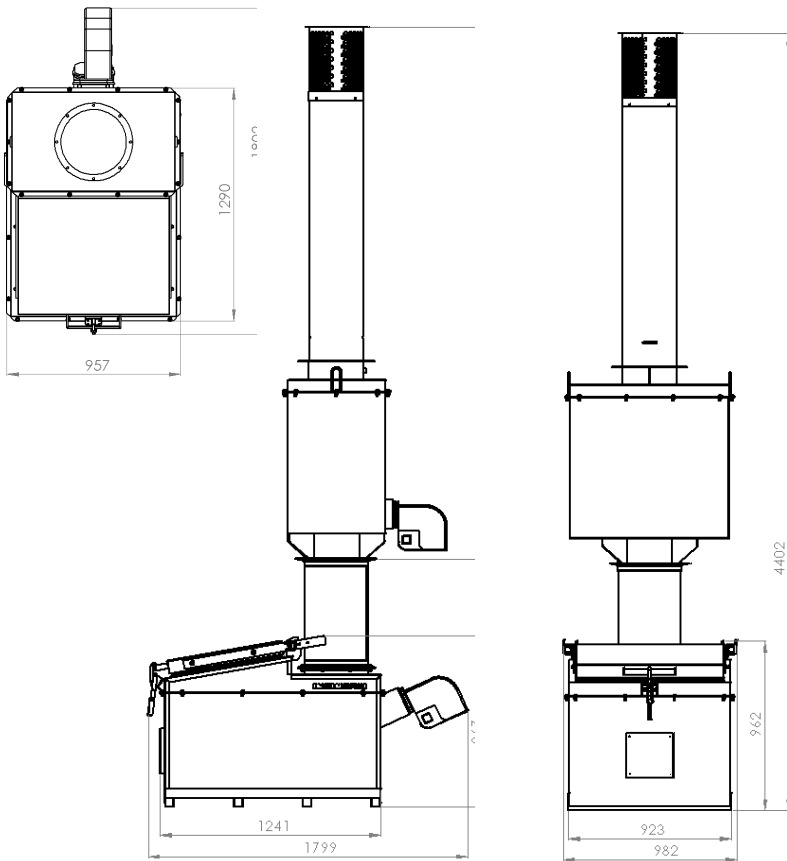

Average emissions / EU standards*

*The above figures are guidelines ONLY.

Parameter (1/2 hr av)	Limits	Measured
Total dust	30 mg/m ³	12 mg/m ³
Sulphur dioxide	200 mg/m ³	2.4 mg/m ³
Nitrogen dioxide	400 mg/m ³	60 mg/m ³
Carbon monoxide	100 mg/m ³	78.3 mg/m ³

All our incinerators' chambers are lined with high grade refractory concrete rated to 1600°C. Our secondary chamber technology prevents dioxins from cracking into smaller but more reactive molecules, this is known as de novo formation.

This can be especially apparent in the presence of heavy metals, which can act as a catalyst.

The prevention method can be explained as follows: system design forces the micro particulates to pass through a flame curtain, this burns harmful emissions, gas remnants are then retained in the secondary chamber, through thermal decomposition, and complex, controlled air distribution to ensure a clean odourless emission.

Incinerator Specification

Combustion Chamber Volume (m3)	0.36 m ³
Metal Thickness	3mm
Burn Rate**	up to 30kg per hour
Operational Temperature	850°C
Gas Retention	2 seconds
Average Ash Residue (%)	3%
Thermostatic Device(s)	yes (x2)
Shipping Weight (kg)	1520kg
Dimensions (l, w, h)	1.24m x 0.92m x 4.4m
Door Size	0.56m x 0.56m
Fuel Consumption	8 - 10 ltrs per hour
Fuel Types	Light Oil, Diesel, Kerosene, Gas, LPG
Max Sound Output (dB)	65 dB
Max Electrical Consumption (kWh)	0.115kW



** PLEASE NOTE:

Actual burn rates & emissions will depend on a number of factors including waste type, volume of waste, moisture content, fuel used and local environmental conditions.

Burner Specification:

This model is fitted with 2 burners (1 x MAX 8 TC, 1 x MAX 25 TL) as standard to ensure a complete and clean burn cycle. Ecoflam products ensure high efficiency and reliable operation combined with functional features that reduce installation time and maintenance and grant a flexible boiler/ burner matching.



Ecoflam

- MAX 1-12 have electrical frequency 50-60 Hz
- High efficiency fan ventilation system (HPV)
- Low NOx version class 3 with yellow flame
- Designed in compliance with current regulations
- ISO 9001 and VISION 2000 certification
- All burners are fire tested

NB: picture for illustration purposes only



For additional information, or to speak to one of our expert team:

Call
+44 (0) 1704 884020

Email
sales@inciner8.com

INCINER8
www.inciner8.com

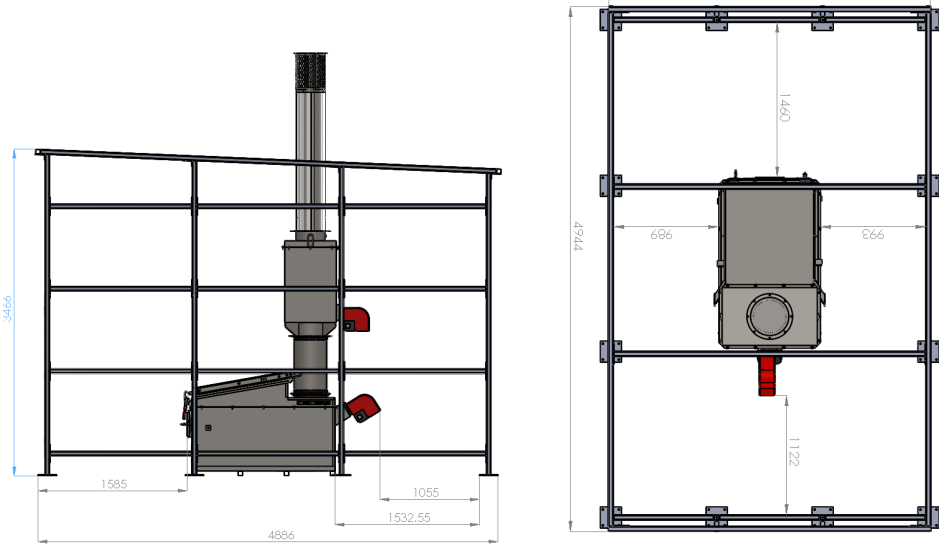

- Concrete floor is preferred for installation, this should be solid and levelled.
- If you construct a new base then a reinforced concrete slab 20cm thick is recommended.
- Replace the material at a depth of at least 50cm
- Apply gravel and compact to the compressibility modulus $M = 80.0 \text{ MN/m}^2$.
- All fuel and electrical installations should be done according to local regulations.
- A basic shelter is required to protect the incinerator and the control panel from the weather.

Groundwork required

Step 1
Mark out area for base and reinforce with steel mesh.



Step 2
Concrete and allow 24-48 hours to dry fully before installation.



Step 3
Assemble incinerator shelter on concrete base once fully dried.



Site Options



Sheltered

Ideal weather protection for equipment and operator. Our shelters are designed for easy and quick installation on a standard reinforced concrete slab.

Certain regions require some sort of shelter from adverse weather conditions or localised problems. Our products are used in diverse locations from the freezing camps of Antarctica to sweltering temperatures of Sierra Leone.



Containerised

Containerisation is the most feasible and viable option in contrast to the construction of on-site facilities and housing structures, eliminating the man power and costs involved.

The units arrive complete with electrical power generators and fuel tank (further customization available to suit all needs). The system is available in 10ft, 20ft, and 40ft containers, depending on optional requirements.



Trailer-mounted

The trailer is rated to carry up to 2700kg, therefore there is plenty of additional space to carry extra items of equipment including generator sets, fuel and any other equipment.

Chassis, framework and panels are galvanized for maximum durability.

The beam axle system features sealed, specialised wheel bearings and powerful auto-reverse brakes and is unequalled for strength and durability.

If you are considering a mobile option its worth bearing in mind that we can supply and install all the required accessories prior to dispatch - such as generators, lighting, power sockets, fuel tanks and piping. This allows rapid deployment of your mobile unit to where it is needed most.



All containers supplied are ISO 6346 certified, so they can be used for the shipping and housing of incinerators and any other related equipment.



For additional information, or to speak to one of our expert team:

Call
+44 (0) 1704 884020

Email
sales@inciner8.com

INCINER8
www.inciner8.com

Annual Spare Parts Package



Your incinerator will last for years if properly looked after and maintained. The simplest way to help it last is to maintain and inspect the machine on regular intervals. Annual service packs vary from machine to machine, but typically consist of: new burners, fire rope, fireproof mastic and refractory cement.

Operators PPE Kit



In most countries you are required by law to wear appropriate PPE equipment when operating machinery and/or handling hazardous or bio-hazardous waste.

Our operators kit contains a heavy duty, fire resistant apron, gauntlets and a face visor.

Emissions Monitoring



In certain situations you will require emissions monitoring. We offer a range of options to match your needs. Our recommended solution is totally portable and gives you an instant insight into the composition of your exhaust gases.

Fuel Tank & Piping Kit



All our incinerators come supplied with burners that have been configured for your chosen fuel type.

We supply a wide range of fuel tanks from 350 litres to 2500 litres and, quality steel braided flexible pipes to allow most kinds of installation.

Pre-Fabricated Shelter



We can provide pre-fabricated shelters constructed from galvanised steel. These come flat packed and require no skills to assemble within just 1 hour.

All incinerators should be on a solid concrete base.

*bespoke solutions incur additional charges for design and engineering work, please speak to your sales agent.

Additional Services



Rewiring / Electrical Repairs

Our Engineers are fully trained to rewire any machine along with fault finding and electrical testing.



Insulation & Refractory Repairs

Due to the design of our refractories, it is very easy to repair these on-site. IN most cases this can be done by a competent operator. However we can easily send an engineer if you do not feel comfortable doing this yourself.

We can also supply complete replacement loading doors, de-ashing door fully concreted and insulated.



Welding, Fabrication & Repairs

Our teams of time-served fabricators can repair or modify your incinerator on-site or back at our factory.

In some regions we offer local fabrication services using local welders and engineers.



Annual Services & Maintenance

Inciner8 are experienced in servicing and repairing most makes of incinerator.

After a successful service, you will be issued with a servicing certificate that lasts for 12 months from the date of the service.



For additional information, or to speak to one of our expert team:

Call
+44 (0) 1704 884020

Email
sales@inciner8.com

 **INCINER8**
www.inciner8.com



Award Winning Team

Here at INCINER8 we see awards as great recognition for the hard work and effort we put in to every order we fulfil. We constantly remind our team that if you work hard and provide excellent customer service you will be recognised.

Over the years we have been privileged to win awards, both regionally, nationally and internationally - and long may it continue.



British Designed & Built



Our Suppliers & Partners

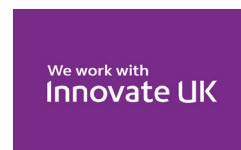

For additional information, or to speak to one of our expert team:

Call +44 (0) 1704 884020

Email sales@inciner8.com



INCINER8 Ltd is one of the largest suppliers of incinerators throughout the world. Manufacturing in a factory in Southport and shipping out products all over the world through our dedicated sales team & Global Dealership Network.

An experienced team of researchers, designers and engineers have made INCINER8 an innovator in the waste incinerator sector, achieving two Queens Awards and many regional business awards. Our hand engineered machines can process municipal, medical and animal waste streams, providing the best solutions to waste problems around the world.



Sales / Head Office

Inciner8 International
2 Canning Rd Industrial Estate
Southport
Merseyside
PR9 7SN

Phone: +44 (0) 1704 884020
Email: enquiries@inciner8.com

Dealerships

If you would like to become part of our dealership network, please get in touch:

Phone: +44 (0) 1704 884020
Email: dealers@inciner8.com

Technical Support

We have a wealth of information regarding our machines, waste disposal best practice and waste composition on our website.

Phone: +44 (0) 1704 884020
Email: techsupport@inciner8.com

